



MODEL RL1600
AUTOMATED TELLER MACHINE
INSTALLATION MANUAL

TDN 07103-00186 Jan 19 2009

CORPORATE HEADQUARTERS:

522 E. Railroad Street
Long Beach, MS 39560
Phone: (228) 868-1317
Fax: (228) 868-0437

COPYRIGHT NOTICE

© 2008 Triton. All Rights Reserved. TRITON logo is a registered trademark of Triton Systems of Delaware.

INTRODUCTION

The Triton RL1600 is a lobby terminal designed for indoor use only. The following sections provide the requirements for installing the RL1600 for your particular site location. To assist you in preparing your site, a check list is provided of various steps that should be carried out **prior** to the arrival of the ATM.

WHAT'S IN THIS INSTALLATION GUIDE

This Installation Guide provides information for the physical installation of the RL1600 ATM. It contains requirements for site preparation, electrical specifications, and cabinet accessibility that comply with all relevant codes, laws and regulations. The Installation Guide is divided into the following sections:

- SITE COMPLIANCE.** States the customers responsibilities for ensuring all relevant regulations are adhered to for installing ATMs.
- ATM ENVIRONMENTAL PRECAUTIONS CHECKLIST.** Describes the general environmental precautions considered when installing the ATM. To help ensure proper operation of the ATM, ensure the environmental criteria listed in this checklist are met.
- DIMENSIONS.** Describes physical dimensions for the cabinet(s), control panel components, and signage.
 - Physical dimensions.
 - Service area dimensions.
 - Customer access dimensions
- INSTALLATION.** Describes anchoring the cabinet using standard (steel) or the optional chemical anchors. **(Anchors provided separately)**
- Dispensing Mechanism Installation.** The Minimech dispensing mechanism is factory installed.
- POWER AND COMMUNICATION.** Shows cable access area, power requirements, and powering-up the unit.
- APPENDIX A.** Software License Agreement / Compliance/Emissions statements
- APPENDIX B.** ATM Installation for Accessibility guidelines.

CONTENTS

SITE COMPLIANCE4

ENVIRONMENTAL PRECAUTIONS5

TEMPERATURE / POWER / RF INTERFERENCE REQUIREMENTS.....6

DIMENSIONS.....7

FRONT VIEW / CUSTOMER ACCESS DIMENSIONS8

SERVICE AREA DIMENSIONS9

SHALLOW CABINET (BUSINESS HOURS)

SIDE VIEWS10

MID TOPPERS12

CABINET ANCHOR “FOOTPRINT” 12

CABINET INSTALLATION13

TOOLS REQUIRED14

UNPACKING THE UNIT14

MARK / DRILL MOUNTING HOLES.....16

INSTALLING STANDARD ANCHORS / BOLT ATM.....17

INSTALL CHEMICAL ANCHORS / BOLT ATM18

ROUTE POWER / COMMUNICATION CABLES.....21

ROUTE / CONNECT CABLES.....22

APPENDIX A - SOFTWARE LICENSE AGREEMENT / COMPLIANCE/EMISSIONS STATEMENTS

APPENDIX B - ATM INSTALLATION FOR ACCESSIBILITY

SITE COMPLIANCE

This document contains the information necessary for the preparation and installation of an RL1600 Triton ATM. It's important that the site complies with the requirements specified in this document. In addition, electrical wiring and mechanical systems must also comply with all relevant laws and regulations.

The site must be prepared by the customer or his agent who is fully conversant with the requirements of installing ATM equipment. The responsibility for ensuring that the site is prepared in compliance with this document remains with the customer.

For information and guidance only, a list is provided in general terms of those matters for which the customer is responsible. The list is not intended to be comprehensive and in no way modifies, alters, or limits the responsibility of the customer for all aspects of adequate site preparation.

1. Location of the equipment and site preparation.
2. Site wiring (power, communication). Ensure access will not be hindered by cabinet placement.
3. Location of other equipment that may cause electrical, electromagnetic or heat induced interference.
4. Make building alterations to meet wiring and other site requirements.
5. Install all communication cables, wall jacks, and associated hardware.
6. Provide and install necessary power distribution boxes, conduits, and grounds.
7. Ensure all applicable codes, regulations, and laws (electrical, building, safety) are adhered to.
8. Ensure the environmental requirements of this unit are met.
9. Install the unit at a height which meets the ADA/DDA/CSA accessibility regulations for the state/country installed. Refer to Appendix B.

SITE PREPARATION CHECKLIST	
Select site and design a floor plan	
Ensure environmental conditions met	
Establish contractor and vendor schedules	
Check communication line requirements	
Plan installation accessory needs	
Check floor plan and make necessary alterations	
Install electrical requirements	
Prepare site for communication needs	
Plan operator training (optional)	
Install communication lines and test	
Ensure installation accessories are available	

ENVIRONMENTAL PRECAUTION CHECKLIST

When installing an ATM, some general environmental and power precautions need to be considered. Evaluate the location where the ATM will be installed. To help ensure proper operation of the ATM, ensure the environmental criteria listed in this checklist are met.

TEMPERATURE / HUMIDITY

1. **The ATM will operate over a range of temperatures and humidity. Generally, these parameters must fall within the following ranges:**

Temperature

- 10°C to 40°C
- 50°F to 104°F

Relative Humidity

- 20% to 80%
- (Non-Condensing)

AC POWER REQUIREMENTS

2. **Ensure the following AC power requirements are met:**

Current (Max)

- 2.2A @ 115 VRMS at 60 Hz
- 1.1A @ 230 VRMS at 50 Hz

Voltage

- 90 - 136VRMS @ 50/60 Hz
- 198 - 257VRMS @ 50/60 Hz

Power Consumption (Idle)

- 0.6A @ 115 VAC at 60 Hz
- 0.3A @ 230 VAC at 50 Hz

Power Consumption (Max Load)

- 250 Watts @ 120VAC
- 250 Watts @ 240VAC

Surge ~50A @ 230V

*** IMPORTANT ***

AC power for the terminal should come from a dedicated source with an isolated ground.

Dedicated source. The ATM AC power feed will be a dedicated line, to which no other electrical devices are connected. The ATM power line will be wired for a single “duplex”-style outlet and connected directly to the AC service panel. (No extension cords)

Isolated Ground. An equipment grounding conductor that is insulated from the conduit or raceway and all other grounding points throughout its entire length. The only points of electrical connection will be at the duplex outlet and service panel ends of the line.

DEDICATED TELEPHONE

3. **Ensure the following telephone-line requirements are met:**

Dedicated line. The telephone line servicing the ATM will not be a “party” line or any other shared type connection.

Proximity to Interference Sources. The telephone line must not be in close proximity to “noisy” devices that could induce interference into the ATM communications channel. See the next section for additional information on “interference sources.”

RF INTERFERENCE

4. **Ensure there are no devices near the terminal that may cause RF interference, such as:**

- TVs
- Coolers
- Security devices
- Neon signs
- Devices with compressors or motors.

DIMENSIONS

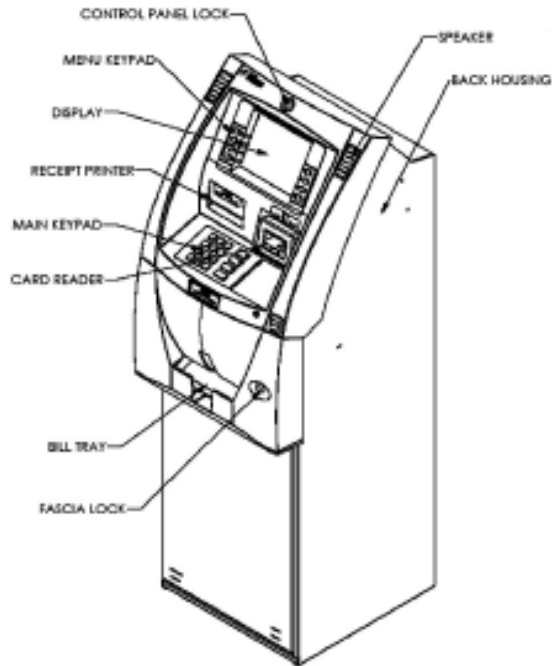

PHYSICAL DIMENSIONS

Front View

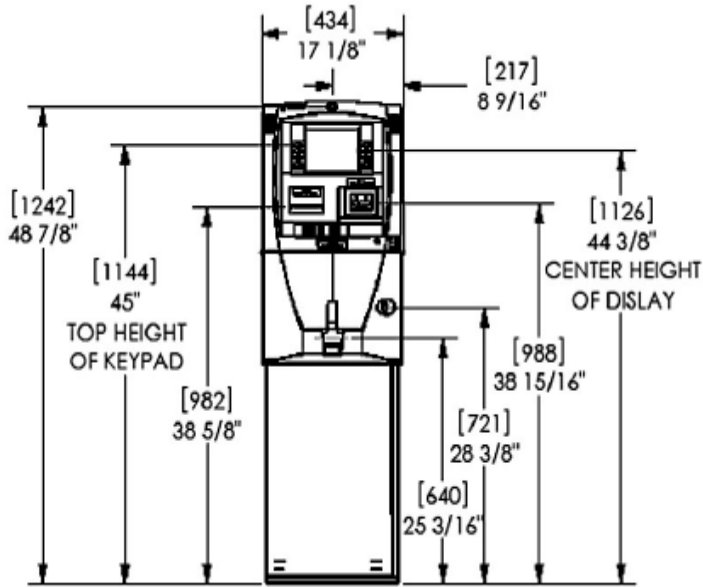

Customer Access Dimensions		
	Feature	Height
1	Top Function Key	45" [1144 mm]
2	#5 Key (Main Keypad)	36" [914 mm]
3	Card Reader	38 - 15/16" [988 mm]
4	Receipt Printer	38 - 5/8" [982 mm]
5	Bill Tray	25 - 3/16" [640 mm]

Dimensions listed comply with US Federal ADA Guidelines. For USA installations, check for additional guidance. For non-USA installations, check regulations relating to the country of install.

Note:
Dimensions shown in inches and [millimeters]

SERVICE AREA DIMENSIONS

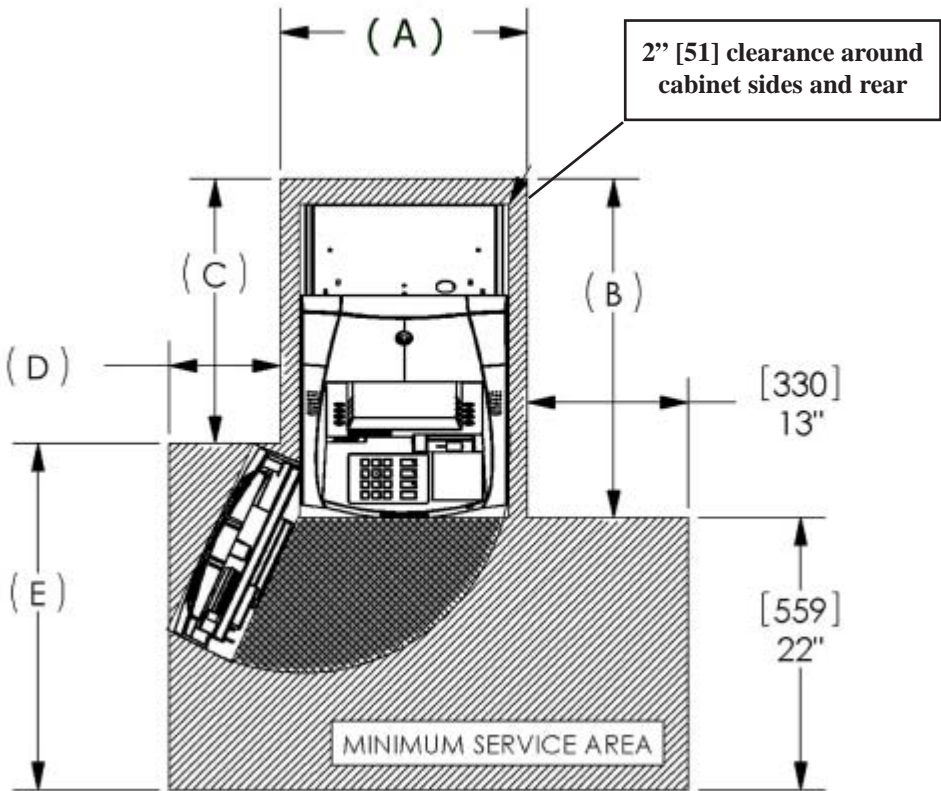

Dimensions Shown in inches (") and [millimeters]	
Dimension	Business Hours
A	~ 21" [533]
B	27-3/8" [696]
C	21-3/8" [543]
D	9" [229]
E	28" [711]

PHYSICAL DIMENSIONS
(SHALLOW CABINET - BUSINESS HOURS)

Side Views

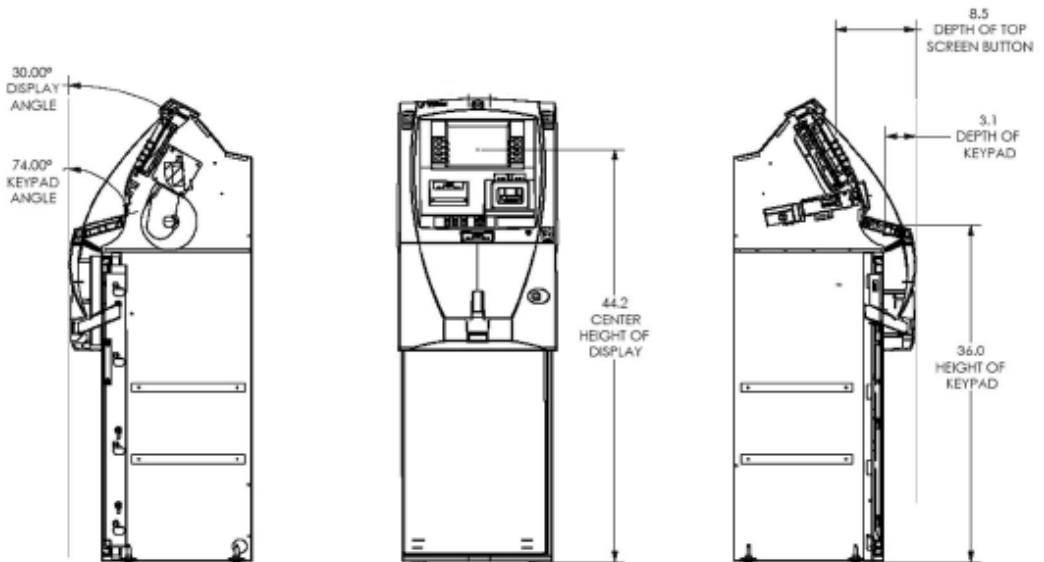
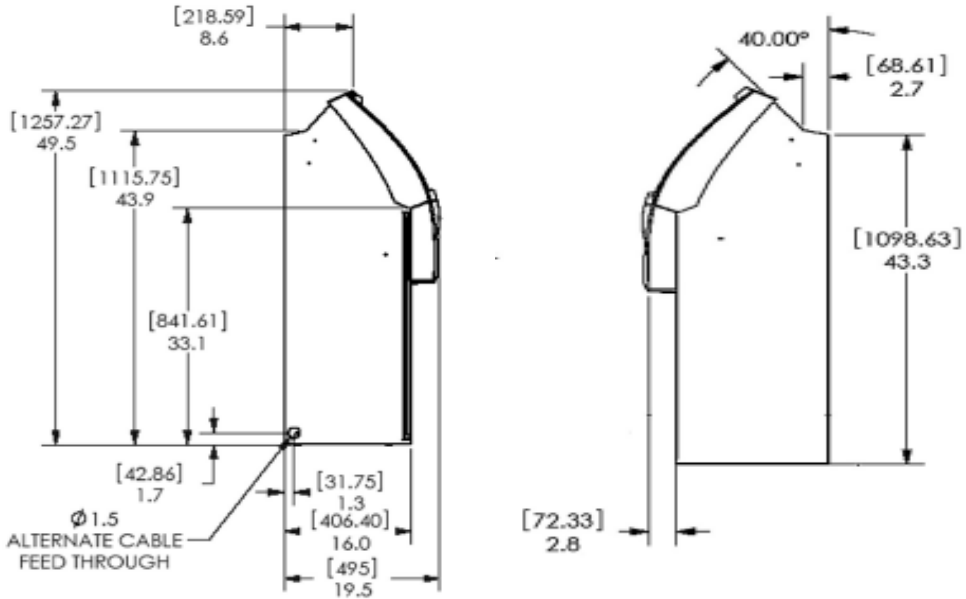

**PHYSICAL DIMENSIONS
(SHALLOW CABINET - BUSINESS HOURS)**

Mid Topper

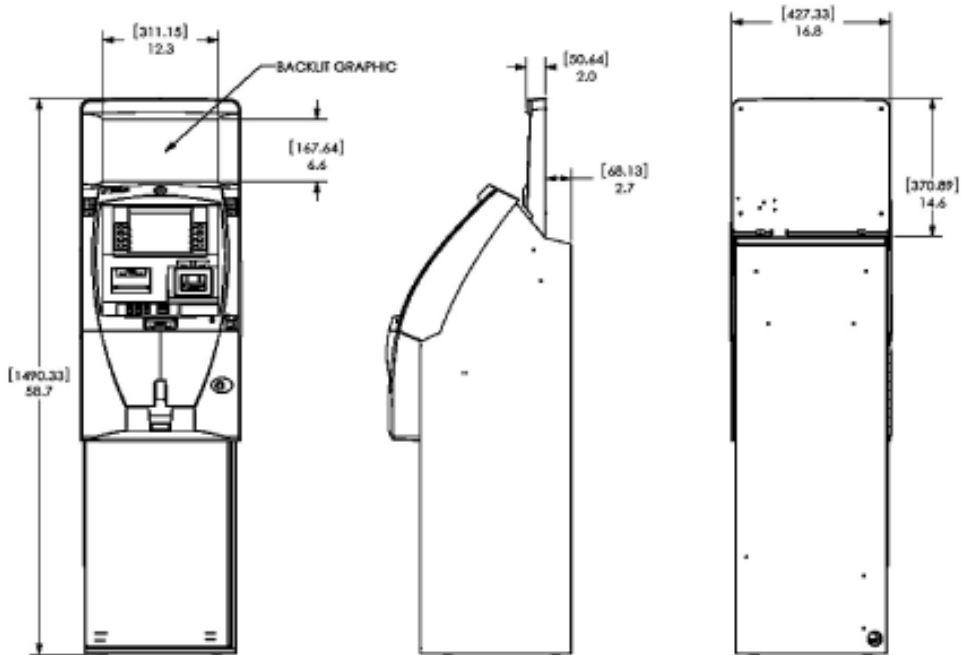

Refer to the enclosed installation instructions in the topper box for installation of the topper onto the cabinet.

CABINET "FOOTPRINT"

Anchor "footprint" - Shallow cabinet (Business)

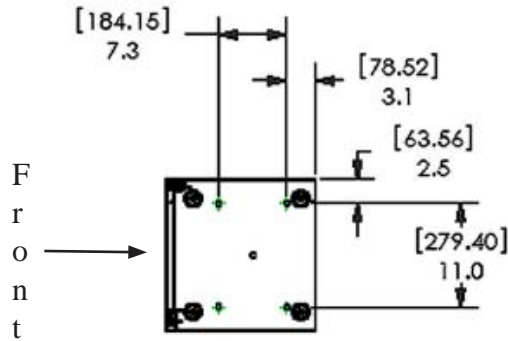

CABINET INSTALLATION

CABINET INSTALLATION

The following procedure applies to installing the cabinet assembly using either standard (P/N 06200-00066) or chemical (06200-00060) anchor kits. The anchor kits **are not** supplied with the unit.

*** IMPORTANT ***
 Model RL1600TM is designed for INDOOR use only!

Tools Required		
Torque wrench, adjustable to at least 60 foot pounds, adjustable crescent wrench, or ratchet wrench		
Center punch (or equivalent) for marking drill points		
Hammer	3/4" (19 mm) socket	Large flat screwdriver
Bubble level	7/16" socket / box wrench	Safety goggles
Hearing protection	1/4" (6 mm) , 1/2" (12 mm), and 9/16" (15 mm) carbide-tipped masonry drill bits - at least 6" long	3/4" heavy -duty electric drill (rotary/hammer)
Back support belt	Portable vacuum cleaner	Wire brush
Standard Anchor Kit		
1/2" flat washers	1/2" x 4-1/4" sleeve-type anchor bolts	1/2" nuts
Chemical Anchor Kit		
Hex nuts and washers	Chemical anchor capsules	Threaded chisel-point rods

UNPACK ATM

1. Carefully inspect the shipping container for any damage and report any damage immediately to the shipping company. Refer to the warranty information in the User or Service manual (as applicable) for information about reporting shipping damage.
2. Remove the ATM cabinet from the carton by cutting the straps and removing the top of the box.
3. Remove the packing material from inside of the box.
4. Remove the silver key from the white plastic bag attached to the ATM wrapping.

5. Stand the unit up and walk it out of the shipping carton.
6. Remove the wrapping from the ATM.
7. Use the silver key to unlock both the control panel and the fascia door (which conceals the locking mechanism) on the front of the cabinet. Open the fascia door.
8. Lift the handle under the bill chute to open the front enclosure door. If the door is locked, see the sidebar on this page for help in unlocking the electronic or mechanical lock, if applicable..
9. Remove the packing material from inside the vault enclosure. Next, carefully remove the dispensing mechanism shipping container for the Mini Mech if required. Inspect the container and dispenser and report any damage to Triton. Set the mechanism aside. This will be installed in later steps.
10. The accessory box is shipped inside the cabinet enclosure. Open and inspect the contents. Check the contents against the enclosed packing list and report any missing parts to Triton.

****WARNING****

DO NOT APPLY POWER TO THIS TERMINAL UNTIL THE INSTALLATION IS COMPLETE!!

UNLOCKING COMBINATION LOCKS

Mechanical Lock. There are two marks on the dial ring. The index mark at the top of the dial is used for opening the lock. A revolution is counted each time the selected number is aligned with the opening index..

Locks are shipped on a factory setting of '50'. To unlock, turn the dial to the left (counterclockwise) **FOUR** (4) turns, stopping on '50'. Then turn the dial to the right (clockwise) until the bolt is retracted.

Electronic Lock. The combination of the lock is preset to **1-2-3-4-5-6**. To unlock, enter the preset combination and check for proper operation. After each keypress, the lock will 'beep'. After the final digit has been entered, the lock will beep twice, and the open period begins. When a valid combination has been entered, the operator will have approximately 3 seconds to open the lock. To open the lock, turn the outer ring of the dial clockwise. After the lock is opened, the vault door may be opened.

Mark/Drill Mounting Holes

Mark the location of the cabinet mounting holes on the concrete floor. This is accomplished as described below:

1. Move the ATM to the location where it will be installed.
Open the cabinet vault door at least 90° to improve access. Locate the five (5) anchor-bolt holes in the bottom of the cabinet (each corner and center). Use a felt-tip pen or other marker to carefully mark the center of each of the four corner holes on the floor; these marks will serve as guides for the anchor bolt holes that will be drilled in the next step. Move the ATM aside to provide clear access to the mounting hole marks. Center punch each mark to help align the drill bit.
2. Use a 1/4" [6 mm] diameter carbide-tipped masonry bit to drill four pilot holes at the drilling points marked in the previous step. Drill the pilot holes approximately 1/2" [12 mm] deep into the floor. These holes will help guide the masonry bit that will be used to drill the anchor-bolt holes in the next step.
3. **Standard anchors:** Use a 1/2" [13mm] diameter carbide-tipped masonry bit to drill four holes at least 2-3/4" [70mm] deep into the floor. Be sure to take into account the depth of any floor covering, such as tile or vinyl when gauging the depth of the anchor holes. *Make sure the holes are drilled at least 2- 3/4" [70mm] into the concrete floor.*
- 3a. **Chemical anchors:** Use a 9/16" [15mm] diameter carbide-tipped masonry bit to drill four holes at least 4-1/2" [115mm] deep into the floor. Be sure to take into account the depth of any floor covering, such as tile or vinyl when gauging the depth of the anchor holes. *Make sure the holes are drilled at least 4- 1/2-inches [115mm] into the concrete floor.*
4. **Hole Diameter:** Ensure the holes drilled are not too large in diameter. Test fit the anchor bolts by hand. They should require hammering, **NOT NOW**, and not fall into the hole. Its easier to drill the holes larger now if necessary, than have to move the cabinet and redrill later because they are too big. **DO NOT** be tempted to install the anchors now. It is **VERY** difficult to position the terminal onto the anchors because of the weight.

SELECTING THE INSTALLATION LOCATION

Choosing the right location for your ATM is very important. Security concerns suggest a location that is away from any door or external access point. Ideally, the terminal should be mounted as close to a back wall as possible. For marketing reasons, however, it may be desirable to locate the terminal near the front where your customers can easily locate it. Wherever you decide to locate the terminal, be sure to follow the recommended procedures for both mounting the terminal and for removing cash when the unit will be unattended.

TOOL USE/SAFETY

Observe ALL safety precautions for operating hand and power tools! Wear eye and ear protection while operating the electric drill!

CONCRETE STRENGTH

The floor at the installation location should consist of commercial-grade concrete measuring at least **2000 psi** in compression strength. *The full effectiveness of the mounting anchors depends upon meeting this specification!* Check with the contractor/builder or owner of the installation to verify that this requirement can be satisfied.

5. Use a portable vacuum cleaner to remove any dust or debris that may have fallen into the holes during the drilling process.



Drill anchor holes



Blow or vacuum out dust/debris.

Install Standard Anchors Bolt ATM to Floor

1. Ensure the leveling feet are flush with the bottom of the cabinet. If necessary, use a screwdriver to adjust the leveling bolts inside the cabinet (near the four corners) so that the leveling feet are flush with the bottom of the cabinet.
2. Move the ATM into position for mounting by aligning the base over the four holes drilled in the previous procedure.
3. Place an anchor bolt through the cabinet base and into one of the mounting holes. Use a ball peen hammer to tap the bolt completely into the hole.

IMPORTANT: *If the anchor bolt “falls” into the hole without needing to be tapped in, the hole is too large! The mounting-hole pattern will have to be moved and redrilled using smaller holes as necessary to achieve a snug fit.*

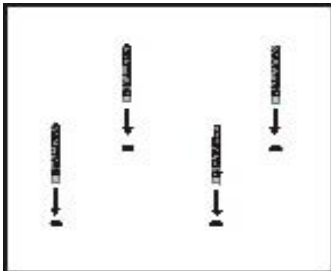

Place anchor bolts in mounting holes.

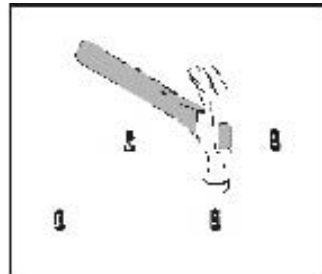

Tap anchor bolts into mounting holes.

- Place a flat washer on the anchor bolt followed by a 1/2" (13mm) nut. Do not tighten fully, allow for leveling.
- Repeat Steps 2 and 3 for the remaining anchor bolts.
- Ensure the cabinet is as level as possible given the floor conditions. Use a bubble level to verify this. If a bubble-level is not available, the cabinet can be "rocked" gently from front-to-back and side-to-side to check the need for leveling. Adjust the leveling feet as necessary.
- Use a torque wrench and 3/4" [19mm] socket to tighten each nut to a torque setting of ***60 foot-pounds (required to establish the maximum pull-out strength of the anchors)***. If a torque wrench is not available, use a ratchet wrench and 3/4" [19mm] socket to tighten the nuts ***three full turns beyond hand tight***. Do Not overtighten.
- Once the nuts are tightened as specified in Step 7, ***install a second nut on each bolt, to act as a jam nut, and tighten down firmly.***

Install Chemical Anchors Bolt ATM to Floor

- Move the ATM into position for mounting by aligning the base over the four holes drilled in the previous procedure. Ensure the leveling feet are even with the bottom of the cabinet.
- Begin by inserting a Chem Stud capsule into one of the mounting holes. Either end of the capsule may be inserted first.
- Place a washer and a nut (in that order) onto a chisel point rod. Thread the nut onto the rod, leaving 3 to 4 threads exposed.
- Thread the rod coupler onto the threaded rod until it is tight against the nut. The threaded rod used should be free of dirt, grease, oil or other foreign material.
- Select the drive unit, insert it into a rotary hammer drill and engage the coupling to be used.

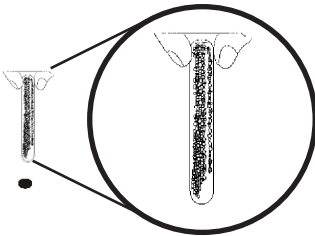

Insert Chem Stud capsule in mounting hole.

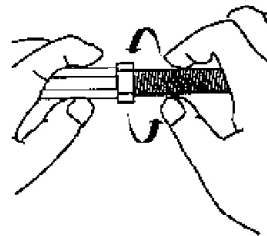

*Prepare chisel point anchor rod.
Add washer and nut.*

6. Insert the chisel point of the rod into the hole to break the glass capsule. Spin it into the capsule at a speed of **250 to 500 RPM**, until it is fully embedded. **IMPORTANT! Turn the rotary hammer drill OFF IMMEDIATELY when the rod is fully embedded or it will strip out!**
7. Pull the driver out of the coupling while holding the rod. Hold the hex nut with a wrench to unthread the coupler.
8. Repeat steps 1-7 for each of the remaining mounting holes.
9. Allow the adhesive to cure for the specified time (see chart and important note, which follows) prior to applying any load to the anchors. During the winter, the hole temperature may be different than the room temperature! The hole temperature should be measured to determine the curing time required. **DO NOT disturb or load the anchors until they are fully cured!**



Allow seated anchor to cure.

Base Material Temperature	Setting Time
68° F/ 20° C or above	20 minutes
50° F/ 10° C to 68° F/ 20° C	30 minutes
32° F/ 0° C to 50° F/ 10° C	1 hour
23° F/ -5° C to 32° F/ 0° C	5 hours
14° F/ -10° C to 23° F/ -5° C	10 hours

10. Ensure the ATM is as level as possible given the floor conditions. Use a bubble level to verify this. If a bubble-level is not available, the cabinet can be “rocked” gently from front-to-back and side-to-side to check the need for leveling. Adjust the leveling feet as necessary.
11. Use an adjustable wrench or a ratchet wrench with 3/4” [19mm] socket to tighten the nuts down. **No minimum torque setting for the nuts is required.** Simply ensure the nuts are tightened down firmly enough to secure the plinth to the anchors. Tightening the nuts just beyond hand tight should prove adequate.
12. Once the ATM is square (level), install a second nut on each bolt and tighten down firmly.

Refer to the enclosed installation instructions in the topper box for installation of the topper onto the cabinet.

THIS PAGE INTENTIONALLY LEFT BLANK

ROUTE POWER AND COMMUNICATION

Route AC Power and Communication Cable

NOTE: Before you start, unlock and open the control panel. Verify that the power switch on the unit's power supply is in the **OFF** (0) position. Close the control panel.

1. Route the AC power cord and the phone (or Cat-5) cable through either the main or alternate cable access hole (as applicable).
2. Connect the AC power cord and communication cable to their respective facility outlets.
3. Secure/plug the unused access hole with the grommet or plug provided.

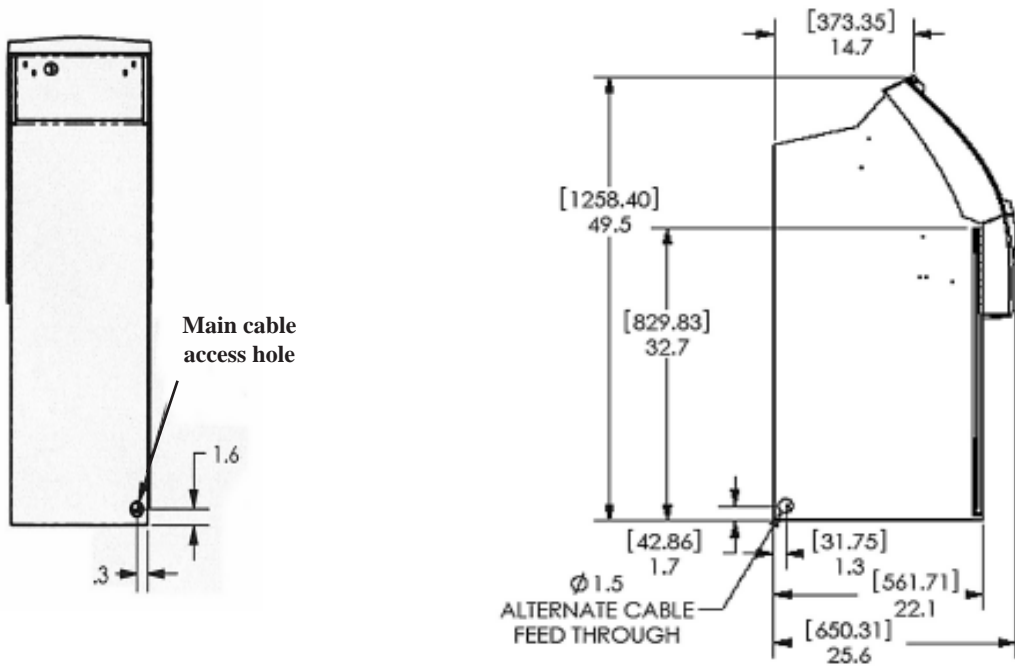

This unit may be equipped with more than one power cord. **Disconnect All Power Cords prior to Servicing!** For continued fault protection, follow the correct voltage and current ratings when replacing any fuses.

Power Outlet Accessibility

Whether you are installing a new AC socket outlet or plan to use an existing outlet to supply power to the ATM, make sure the following requirements are met:

1. The outlet is located near the equipment. Extension cords are not recommended.
2. AC power for the terminal should come from a dedicated source with an isolated ground. The ATM is designed to work on an IT (Isolated-Terra) type power system having a phase-to-phase voltage not exceeding 240 volts.
3. The outlet is easily accessible and will not be blocked once the equipment is installed and anchored.

POWER SUPPLY CORD - SPECIFICATIONS

For European applications, the power supply cord must conform to the following specifications:

1. Two-conductor with Physical Earth (PE) ground.
2. IEC 320 molded connector on one end and molded plug on the other end.
3. Certified for country of installation.
4. Rated minimum H05VV-F with minimum 0.75 mm² (except where specific countries require 1.0 mm²) conductors.
5. Maximum length: 3 meters.

**REFER TO THE USERS MANUAL
AND CONFIGURATION MANUAL
FOR OPERATIONAL
INSTRUCTIONS**

APPENDIX A
SOFTWARE LICENSE AGREEMENT
COMPLIANCE / EMISSION STATEMENTS

**AUTOMATED TELLER MACHINE (“ATM”) SOFTWARE
END-USER AGREEMENT**

IMPORTANT: PLEASE READ CAREFULLY:

BY INSTALLING OR OTHERWISE USING THE ATM, YOU (AS THE OWNER OR LESSEE OF THE ATM), AGREE TO BE BOUND BY THE FOLLOWING TERMS AND CONDITIONS, INCLUDING, WITHOUT LIMITATION, THE WARRANTY DISCLAIMERS, LIMITATIONS OF LIABILITY AND TERMINATION PROVISION WHICH APPLY TO YOUR USE OF THE ATM SOFTWARE CONTAINED IN THIS ATM AND IS HEREBY LICENSED BY TRITON SYSTEMS OF DELAWARE, INC. (“Triton”) TO YOU PURSUANT TO THIS AGREEMENT.

IF YOU DO NOT AGREE TO OR ARE NOT WILLING TO BE BOUND BY THE TERMS AND CONDITIONS OF THIS AGREEMENT, DO NOT INSTALL OR OTHERWISE USE THIS ATM AND PROMPTLY CONTACT YOUR VENDOR. INSTALLING OR OTHERWISE USING THE ATM INDICATES THAT YOU ACCEPT THESE TERMS.

This ATM is manufactured by, and utilizes proprietary software owned by Triton Systems of Delaware, Inc. and/or its suppliers. All right, title and interest in and to all component software installed or embedded in the ATM (“ATM Software”) including all associated intellectual property rights, are and will remain the property of Triton and/or its suppliers.

LICENSE: Triton grants you a limited, nonexclusive license to use the ATM Software but only in connection with the operation of this ATM subject to the terms and restrictions set forth in this License Agreement. You are not permitted to use the ATM Software in any manner not expressly authorized by this License. You acknowledge and agree that ownership of the ATM Software and all subsequent copies thereof regardless of the form or media are held by Triton or its suppliers.

The software is licensed for use on this specific Triton ATM product and may not be used on any other product. Otherwise, the supporting documentation, if any, may be copied only as essential for backup or archive purposes in support of your use of the ATM. You must reproduce and include all copyright notices and any other proprietary rights notices appearing on any copies that you make.

ASSIGNMENT: NO REVERSE ENGINEERING: You may transfer the ATM Software to another party but only in connection with a transfer of all your right, title and interest in and to this ATM and if such party accepts the terms and conditions of this License Agreement. If you transfer the ATM, you must at the same time transfer the supporting documentation, if any, to the same party or destroy any such materials not transferred. Modification, reverse engineering, reverse compiling, or disassembly of the ATM and/or the ATM Software is expressly prohibited.

DISCLAIMER OF WARRANTIES AND LIMITATION OF DAMAGES

TO THE EXTENT PERMITTED BY LAW, THIS ATM SOFTWARE, INCLUDING ALL INCORPORATED THIRD PARTY SOFTWARE, AND DERIVATIVES IS PROVIDED, "AS IS". TRITON MAKES NO REPRESENTATIONS WITH RESPECT TO, AND DOES NOT WARRANT THE PERFORMANCE OR RESULTS YOU OR YOUR CUSTOMERS MAY OBTAIN BY USING THE ATM. TRITON SPECIFICALLY DISCLAIMS ANY AND ALL WARRANTIES, EXPRESS, IMPLIED OR STATUTORY, INCLUDING WITHOUT LIMITATION, WARRANTIES OF QUALITY, PERFORMANCE, NONINFRINGEMENT, AND MERCHANTABILITY OR FITNESS FOR ANY PARTICULAR PURPOSE.

TRITON MAKES NO REPRESENTATIONS OR WARRANTIES AND ASSUMES NO OBLIGATIONS TO YOU OR YOUR CUSTOMERS WITH RESPECT TO ANY TRANSACTION OR SERVICES ACCESSED AND/OR UTILIZED IN CONSUMER-INITIATED TRANSACTIONS MADE FROM THIS ATM. IN NO EVENT WILL TRITON, ITS AFFILIATES, DIRECTORS, OFFICERS, EMPLOYEES, AGENTS OR SUPPLIERS BE LIABLE TO YOU UNDER ANY THEORY OF TORT, CONTRACT, STRICT LIABILITY OR OTHER LEGAL OR EQUITABLE THEORY FOR ANY PUNITIVE, CONSEQUENTIAL, INCIDENTAL, SPECIAL OR SIMILAR DAMAGES, INCLUDING ANY LOSS PROFITS OR LOST SAVINGS, EVEN IF A TRITON AGENT OR REPRESENTATIVE HAS BEEN ADVISED OF THE POSSIBILITY OF SUCH DAMAGES, OR FOR ANY CLAIM BY ANY THIRD PARTY.

YOUR SOLE REMEDY AGAINST TRITON FOR DEFECTIVE PERFORMANCE OF THE ATM SOFTWARE WILL BE LIMITED EXCLUSIVELY TO REPAIR OR REPLACEMENT OF THE ATM AND/OR THE ATM SOFTWARE, AT TRITON'S SOLE DISCRETION.

Any warranty pertaining to the ATM, its mechanical components exclusive of the ATM software, shall be governed and controlled by any warranty given to you by Triton in a separate document accompanying this ATM.

The foregoing limitation of liability and exclusion of certain damages will apply regardless of the success or effectiveness of other remedies.

GOVERNING LAW: This License Agreement shall be governed by the laws of the State of Mississippi and by the laws of the United States, excluding their conflicts of laws principles.

SEVERABILITY: In the event any provision of this License Agreement is found to be invalid, illegal or unenforceable, the validity, legality and enforceability of any of the remaining provisions shall not in any way be affected or impaired.

ENTIRE AGREEMENT: This License Agreement and the accompanying Limited Warranty set forth the entire agreement between you and Triton, supersedes all prior agreements, whether written or oral, with respect to the ATM Software, and may be amended only in writing signed by both parties.

COMPLIANCE / EMISSION STATEMENTS

DISCLAIMER

The manufacturer of the Automated Teller Machine (ATM) product(s) described herein makes no representations or warranties, either expressed or implied, by or with respect to anything in this manual, and shall not be liable for any implied warranties of fitness for a particular purpose or for any indirect, special, or consequential damages. Information in this document is subject to change without notice and does not represent a commitment on the part of the manufacturer.

**** CAUTION ****

Changes or modifications not expressly approved by Triton Systems could void the regulatory compliance approval and the warranty. Use of this product in a manner other than those described in this manual may result in personal injury!

EMISSIONS (EMI)

(US Requirements)

This device complies with Part 15 of the FCC rules. Operation is subject to the following two (2) conditions:

- 1) This device may not cause harmful interference.
- 2) This device must accept any interference received, including interference that may cause undesired operation.

NOTE:

This equipment has been tested and found to comply with the limits for a Class A digital device pursuant to Part 15 of FCC rules. These limits are designed to provide reasonable protection against harmful interference when the equipment is operated in a commercial environment. This equipment generates, uses, and can radiate radio frequency energy and, if not installed and used in accordance with the instruction manual, may cause harmful interference to radio communications. Operation of this equipment in a residential area is likely to cause harmful interference in which case the user will be required to correct the interference at his own expense. Changes or modifications to this unit not expressly approved by the party responsible for compliance could void the user's authority to operate the equipment.

CANADIAN REQUIREMENTS

This digital apparatus does not exceed the Class A limits for radio noise emissions from digital apparatus set in the Radio Interference Regulations of the Canadian Department of Communications. This Class A digital apparatus complies with Canadian ICES-003.

Le present appareil numerique n'emet pas de bruits radioelectriques depassant les limites applicables aux appareils numeriques de la Class A prescrites dans le Reglement sur le brouillage radioelectrique edicte par le ministere des Communications du Canada. Cet appareil numerique de la classe A est conforme a la norme NMB-003 Canada.

UK / AUSTRALIA / SOUTH AFRICA REQUIREMENTS

Warning:

This is a Class A product. In a domestic environment, this product may cause radio interference in which case the user may be required to take adequate measures.

APPENDIX B
ATM INSTALLATION FOR ACCESSIBILITY

A Guide to the New ADA-ABA Accessibility Guidelines

On July 23, 2004, the U.S. Access Board, an independent Federal agency, issued updated accessibility guidelines for new or altered facilities covered by Americans with Disabilities Act and the Architectural Barriers Act. These guidelines address a wide range of facilities in the private and public sectors. Presented here is an overview of the new guidelines that also highlights significant changes. The following guidelines (305 and 308) pertain to floor/ground space and reach ranges.

When will the new guidelines take effect?

The Board's guidelines are not mandatory on the public, but instead serve as the baseline for enforceable standards (which are) maintained by other Federal agencies. In this respect, they are similar to a model building code in that they are not required to be followed except as adopted by an enforcing authority. Under the ADA, the Department of Justice (and in the case of transit facilities, the Department of Transportation) are responsible for enforceable standards based on the Board's guidelines. These agencies will update their ADA standards based on the new guidelines. In doing so, they will indicate when the new standards are to be followed. Several other agencies (the General Services Administration, Department of Defense, Department of Housing and Urban Development, and the U.S. Postal Service) hold a similar responsibility for standards used to enforce the ABA.

Existing Facilities

The ADA and ABA guidelines cover new construction and planned alterations and generally do not apply to existing facilities except where altered. Facilities built or altered according to earlier versions of the ADA or ABA standards will not necessarily have to meet the updated version except where they are subsequently altered or renovated. The Department of Justice, which regulates requirements for existing facilities under the ADA, intends to address coverage of facilities built or altered according to the original ADA standards in its rulemaking to update the standards. It will also address facilities retrofitted under ADA provisions for existing facilities, such as the requirement for barrier removal in places of public accommodation. With respect to ABA facilities, the Board has clarified in the guidelines that facilities built to earlier ABA standards are subject to the new requirements only in relation to planned alterations.

305. Clear Floor or Ground Space

305.1 General. Clear floor or ground space shall comply with 305.

305.2 Floor or Ground Surfaces. Floor or ground surfaces of a clear floor or ground space shall comply with 302. Changes in level are not permitted.

EXCEPTION: Slopes not steeper than 1:48 shall be permitted.

305.3 Size. The clear floor or ground space shall be 30 inches (760 mm) minimum by 48 inches (1220 mm) minimum.

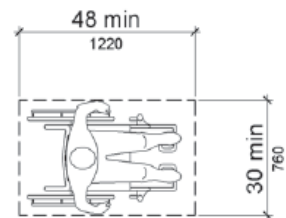

Figure 305.3 Clear Floor or Ground Space

APPENDIX B - ATM INSTALLATION FOR ACCESSIBILITY

305.4 Knee and Toe Clearance. Unless otherwise specified, clear floor or ground space shall be permitted to include knee and toe clearance complying with 306.

305.5 Position. Unless otherwise specified, clear floor or ground space shall be positioned for either forward or parallel approach to an element.

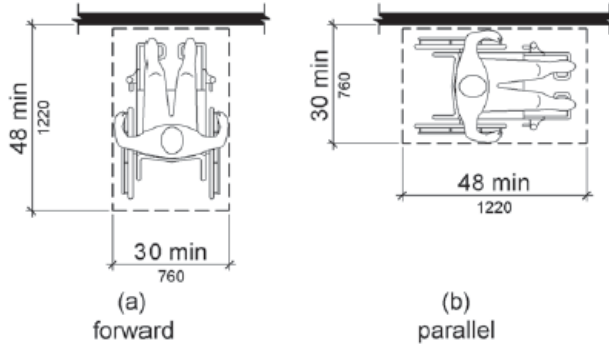

Figure 305.5 Position of Clear Floor or Ground Space

305.6 Approach. One full unobstructed side of the clear floor or ground space shall adjoin an accessible route or adjoin another clear floor or ground space.

305.7 Maneuvering Clearance. Where a clear floor or ground space is located in an alcove or otherwise confined on all or part of three sides, additional maneuvering clearance shall be provided in accordance with 305.7.1 and 305.7.2.

305.7.1 Forward Approach. Alcoves shall be 36 inches (915 mm) wide minimum where the depth exceeds 24 inches (610 mm).

305.7.2 Parallel Approach. Alcoves shall be 60 inches (1525 mm) wide minimum where the depth exceeds 15 inches (380 mm).

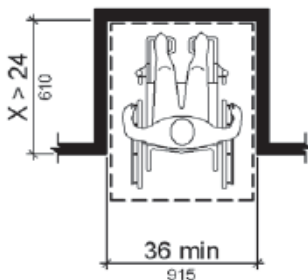

Figure 305.7.1 Maneuvering Clearance in an Alcove, Forward Approach

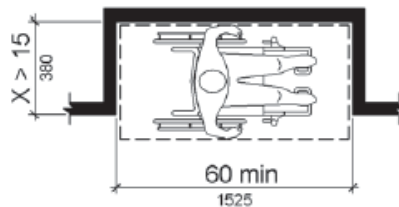

Figure 305.7.2 Maneuvering Clearance in an Alcove, Parallel Approach

308. Reach Ranges

308.1 General. Reach ranges shall comply with 308.

308.2 Forward Reach.

308.2.1 Unobstructed. Where a forward reach is unobstructed, the high forward reach shall be 48 inches (1220 mm) maximum and the low forward reach shall be 15 inches (380 mm) minimum above the finish floor or ground.

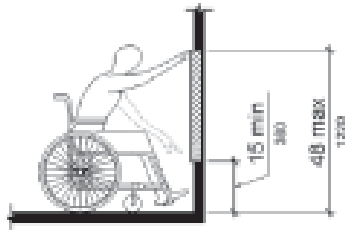

Figure 308.2.1 Unobstructed Forward Reach

308.2.2 Obstructed High Reach. Where a high forward reach is over an obstruction, the clear floor space shall extend beneath the element for a distance not less than the required reach depth over the obstruction. The high forward reach shall be 48 inches (1220 mm) maximum where the reach depth is 20 inches (510 mm) maximum. Where the reach depth exceeds 20 inches (510 mm), the high forward reach shall be 44 inches (1120 mm) maximum and the reach depth shall be 25 inches (635 mm) maximum.

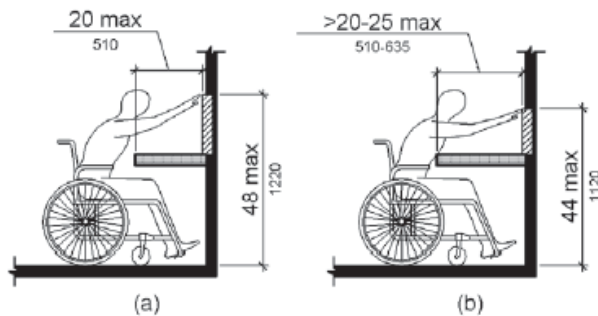

Figure 308.2.2 Obstructed High Forward Reach

APPENDIX B - ATM INSTALLATION FOR ACCESSIBILITY

308.3 Side Reach.

308.3.1 Unobstructed. Where a clear floor or ground space allows a parallel approach to an element and the side reach is unobstructed, the high sidereach shall be 48 inches (1220 mm) maximum and the low side reach shall be 15 inches (380 mm) minimum above the finish floor or ground.

EXCEPTIONS:

1. An obstruction shall be permitted between the clear floor or ground space and the element where the depth of the obstruction is 10 inches (255 mm) maximum.
2. Operable parts of fuel dispensers shall be permitted to be 54 inches (1370 mm) maximum measured from the surface of the vehicular way where fuel dispensers are installed on existing curbs.

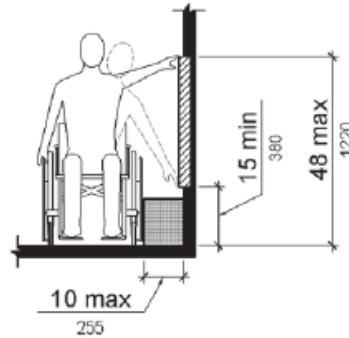

Figure 308.3.1 Unobstructed Side Reach

308.3.2 Obstructed High Reach. Where a clear floor or ground space allows a parallel approach to an element and the high side reach is over an obstruction, the height of the obstruction shall be 34 inches (865 mm) maximum and the depth of the obstruction shall be 24 inches (610 mm) maximum. The high side reach shall be 48 inches (1220 mm) maximum for a reach depth of 10 inches (255 mm) maximum. Where the reach depth exceeds 10 inches (255 mm), the high side reach shall be 46 inches (1170 mm) maximum for a reach depth of 24 inches (610 mm) maximum.

EXCEPTIONS:

1. The top of washing machines and clothes dryers shall be permitted to be 36 inches (915 mm) maximum above the finish floor.
2. Operable parts of fuel dispensers shall be permitted to be 54 inches (1370 mm) maximum measured from the surface of the vehicular way where fuel dispensers are installed on existing curbs.

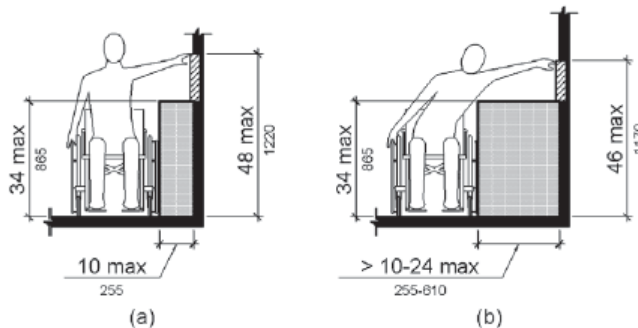

Figure 308.3.2 Obstructed High Side Reach

APPENDIX B - ATM INSTALLATION FOR ACCESSIBILITY

ATM INSTALLATION FOR ACCESSIBILITY

1. This document supersedes all other information provided by Triton for ATM installation for accessibility.
2. Information provided in this manual is based on federal guidelines (ADA Accessibility Guidelines for Buildings and Facilities – ADAAG) as amended through January 1998. You should verify it has not been amended. States may also have accessibility codes. These codes may be more restrictive than the federal guidelines. Please verify this with the state where the ATM is to be installed prior to installation. For state contact information, you may call the ADA information line at 1-800-514-0301.
3. For countries other than the US, please use the guidelines for accessibility for that country.
4. A complete copy of the ADAAG referred to here can be found at <http://www.access-board.gov>. Included in this document is the section of the ADAAG specifically for ATMs. For additional information on floor surfaces and other ADAAG requirements, please see the complete specification.

4.34 Automated Teller Machines.

4.34.1 General. Each automated teller machine machine required to be accessible by **4.1.3 (Accessible Buildings: New Construction)** shall be on an accessible route and shall comply with **4.34 (Automated Teller Machines)**.

4.34.2 Clear Floor Space. The automated teller machine shall be located so that clear floor space complying with **4.2.4 (Clear Floor or Ground Space for Wheelchairs)** is provided to allow a person using a wheelchair to make a forward approach, a parallel approach, or both to the machine.

4.34.3 Reach Ranges.

(1) Forward Approach Only. If only a forward approach is possible, operable parts of all controls shall be placed within the forward reach range specified in **4.2.5 (Forward Reach)**.

(2) Parallel Approach Only. If only a parallel approach is possible, operable parts of controls shall be placed as follows:

(a) Reach Depth Not More Than 10 inches (255 mm). Where the reach depth to the operable parts of all controls as measured from the vertical plane perpendicular to the edge of the unobstructed clear floor space at the farthest protrusion of the automated teller machine or surround is not more than 10 inches (255 mm), the maximum height above the finished floor or grade shall be 54 inches (1370 mm).

(b) Reach Depth More Than 10 inches (255 mm). Where the reach depth to the operable parts of any control as measured from the vertical plane perpendicular to the edge of the unobstructed clear floor space at the farthest protrusion of the automated teller machine or surround is more than 10 inches (255 mm), the maximum height above the finished floor or grade shall be as follows:

APPENDIX B - ATM INSTALLATION FOR ACCESSIBILITY

ACCESSIBILITY SPECIFICATIONS			
REACH DEPTH		MAXIMUM HEIGHT	
Inches	Millimeters	Inches	Millimeters
10	255	54	1370
11	280	53 1/2	1360
12	305	53	1345
13	330	52 1/2	1335
14	355	51 1/2	1310
15	380	51	1295
16	405	50 1/2	1285
17	430	50	1270
18	455	49 1/2	1255
19	485	49	1245
20	510	48 1/2	1230
21	535	47 1/2	1205
22	560	47	1195
23	585	46 1/2	1180
24	610	46	1170

(3) Forward and Parallel Approach. If both a forward and parallel approach are possible, operable parts of controls shall be placed within at least one of the reach ranges in paragraphs (1) or (2) of this section.

(4) Bins. Where bins are provided for envelopes, waste paper, or other purposes, at least one of each type provided shall comply with the applicable reach ranges in paragraph (1), (2), or (3) of this section.

EXCEPTION: Where a function can be performed in a substantially equivalent manner by using an alternate control, only one of the controls needed to perform that function is required to comply with this section. If the controls are identified by tactile markings, such markings shall be provided on both controls.

4.34.4 Controls. Controls for user activation shall comply with **4.27.4 (Operation)**.

4.34.5 Equipment for Persons with Vision Impairments. Instructions and all information for use shall be made accessible to and independently usable by persons with vision impairments.

(20) Where automated teller machines (ATMs) are provided, each ATM shall comply with the requirements of **4.34 (Automated Teller Machines)** except where two or more are provided at a location, then only one must comply.

EXCEPTION: Drive-up-only automated teller machines are not required to comply with **4.27 (Controls and Operating Mechanisms)** and **4.34.3 (Reach Ranges)**.

4.2.4 Clear Floor or Ground Space for Wheelchairs.

4.2.4.1 **Size and Approach.** The minimum clear floor or ground space required to accommodate a single, stationary wheelchair and occupant is 30 inches by 48 inches (760 mm by 1220 mm) (see Fig.4a). The minimum clear floor or ground space for wheelchairs may be positioned for forward or parallel approach to an object (see Fig. 4b and 4c). Clear floor or ground space for wheelchairs may be part of the knee space required under some objects.

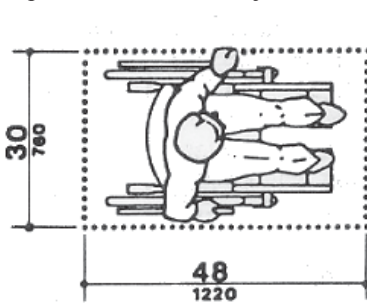

Figure 4a. Clear floor space.

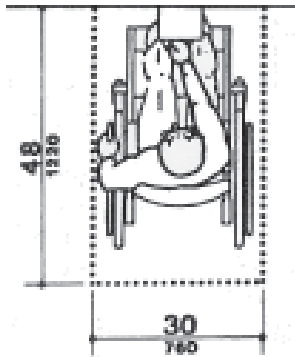

Figure 4b. Forward approach.

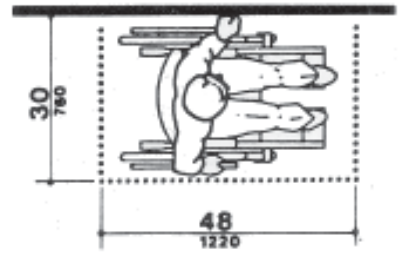
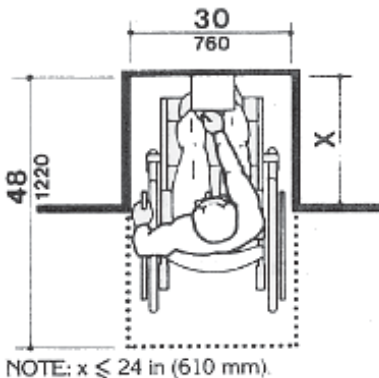
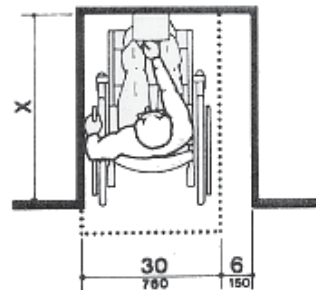

Figure 4c. Parallel approach.

4.2.4.2 **Relationship of Maneuvering Clearance to Wheelchair Spaces.** One full unobstructed side of the clear floor or ground space for a wheelchair shall adjoin or overlap an accessible route or adjoin another wheelchair clear floor space. If a clear floor space is located in an alcove or otherwise confined on all or part of three sides, additional maneuvering clearances shall be provided as shown in Fig. 4(d) and 4(e).



Figures 4d. Clear Floor Space in Alcoves.



Figures 4e. Clear Floor Space in Alcove.

For a front approach, where the depth of the alcove is equal to or less than 24 inches (610 mm), the required clear floor space is 30 inches by 48 inches (760 mm by 1220 mm).

For a front approach, if the depth of the alcove is greater than 24 inches (610 mm), then in addition to the 30-inch (760 mm) width, a maneuvering clearance of 6 inches (150 mm) in width is required.

APPENDIX B - ATM INSTALLATION FOR ACCESSIBILITY

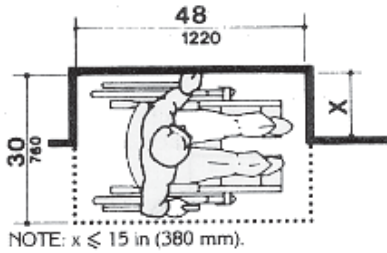

Figures 4d. Clear Floor Space in Alcoves.

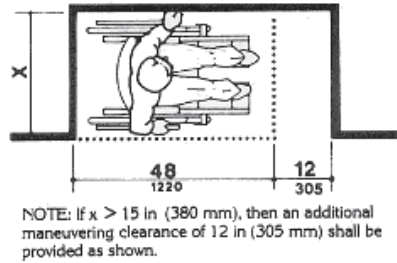

Figures 4e. Clear Floor Space in Alcove.

For a side approach, where the depth of the alcove is equal to or less than 15 inches (380 mm), the required clear floor space is 30 inches by 48 inches (760 mm by 1220 mm).

For a side approach, where the depth of the alcove is greater than 15 inches (380 mm), then in addition to the 48-inch (1220 mm) length, an additional maneuvering clearance of 12 inches (350 mm) is required.

4.2.4.3 Surfaces for Wheelchair Spaces. Clear floor or ground spaces for wheelchairs shall comply with 4.5 (Ground and Floor Surfaces).

4.2.5 Forward Reach. If the clear floor space only allows forward approach to an object, the maximum high forward reach allowed shall be 48 inches (1220 mm) (see Fig. 5(a)). The minimum low forward reach is 15 inches (380 mm). If the high forward reach is over an obstruction, reach and clearances shall be as shown in Fig. 5(b).

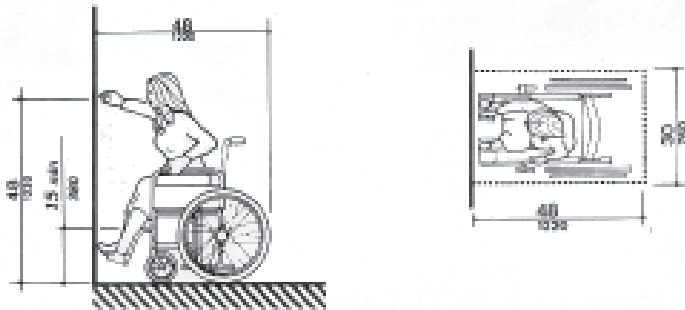
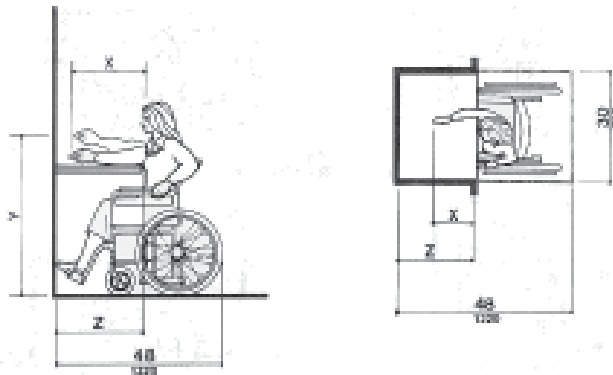

Figure 5a. Forward reach, unobstructed.



NOTE: x shall be 41 to 49 in (1041 to 1245 mm); y shall be 24 to 34 in (610 to 865 mm); z shall be 48 in (1220 mm) maximum. When x is 28 to 34 in (710 to 865 mm), then y shall be 44 in (1118 mm) maximum.

Figure 5b. Forward reach, obstructed.

4.2.6 Side Reach. If the clear floor space allows parallel approach by a person in a wheelchair, the maximum high side reach allowed shall be 54 inches (1370 mm) and the low side reach shall be no less than 9 inches (230 mm) above the floor (Fig. 6(a) and 6(b)). If the side reach is over an obstruction, the reach and clearances shall be as shown in Fig 6(c).

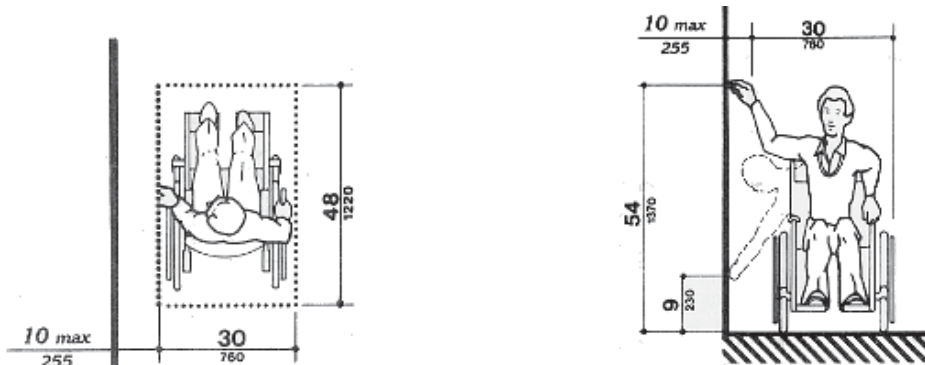
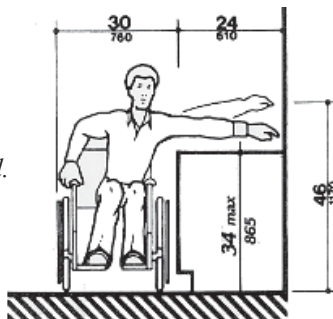

Figure 6a. Parallel approach - side reach.

Figure 6b. Parallel approach - high/low side reach.

Figure 6c. Side reach, obstructed.



APPENDIX B - ATM INSTALLATION FOR ACCESSIBILITY

Outside Handicap Access Area		
48" (1219 mm) - Across -	30" (762 mm) - Deep -	* Measured from center of Control Panel Fascia *

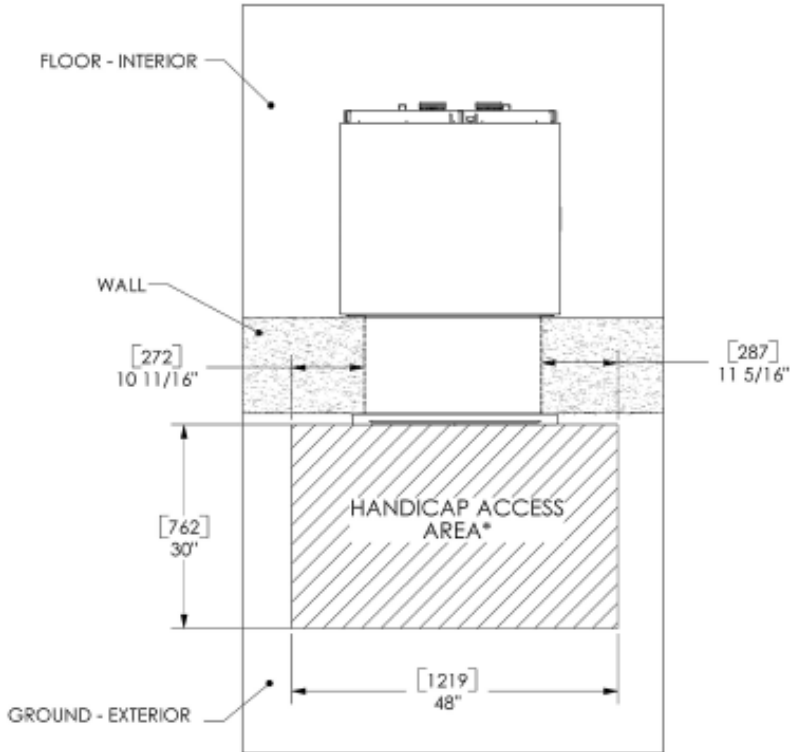

Figure 7. ADA access dimensions for FT7000^{XP} ATM.
(Walk-up / Drive-up)

THIS PAGE INTENTIONALLY LEFT BLANK